

COUPE A-A

ECHELLE 5 : 1

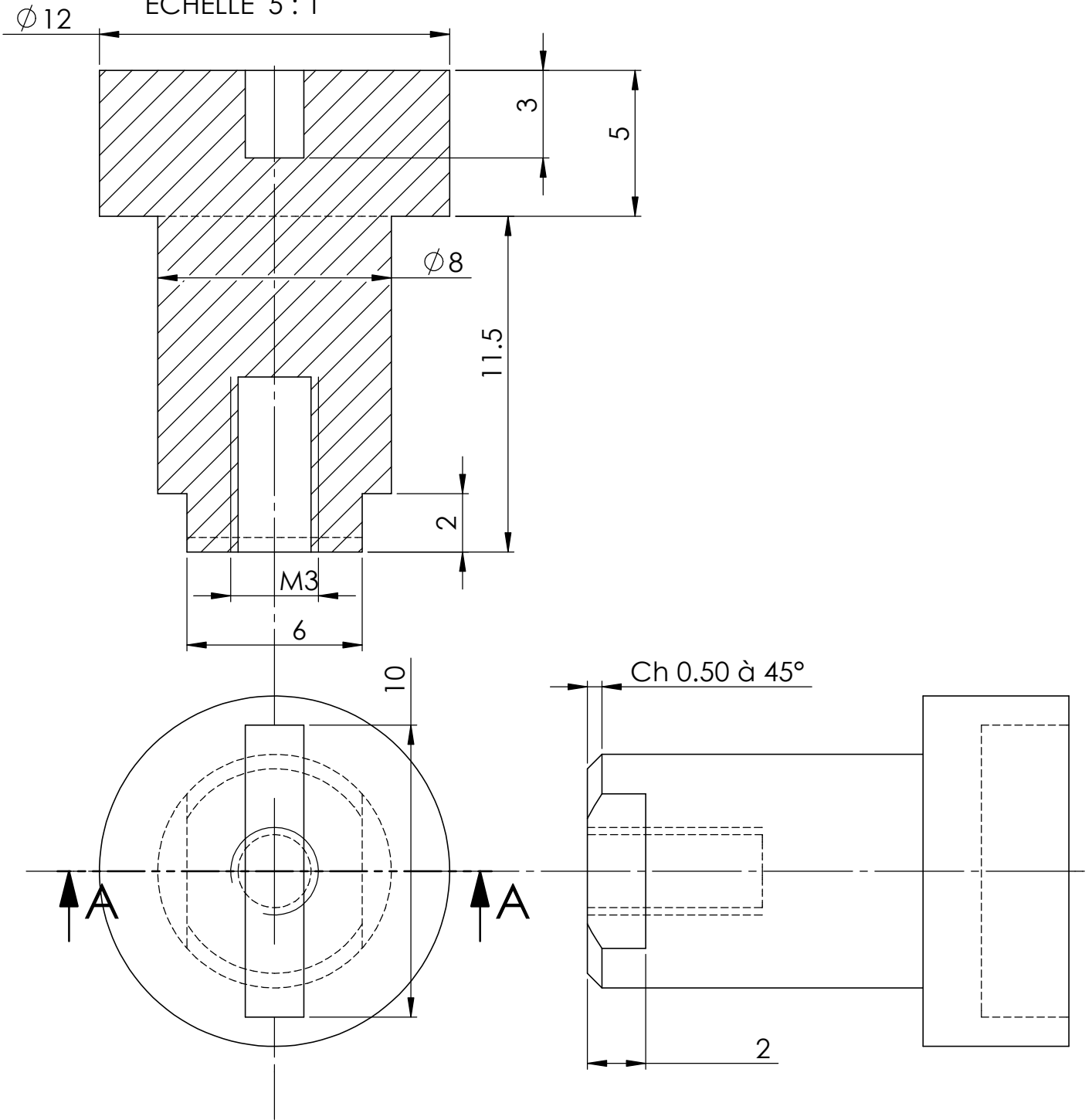

SAUF INDICATION CONTRAIRE: LES COTES SONT EN MILLIMETRES ETAT DE SURFACE: TOLERANCES: LINEAIRES: ANGULAIRES:				FINITION:		CASSER LES ANGES VIFS		NE PAS CHANGER L'ECHELLE		REVISION	
NOM				SIGNATURE		DATE		TITRE:			
AUTEUR								No. DE PLAN			
VERIF.											
APPR.											
FAB.											
QUAL.						MATERIAU:		Bearing shell			
						MASSE:		ECHELLE:2:1		FEUILLE 1 SUR 1	
								A4			